

EKM505020 | 500H 500W 200D,
IP66 Electrical Enclosure

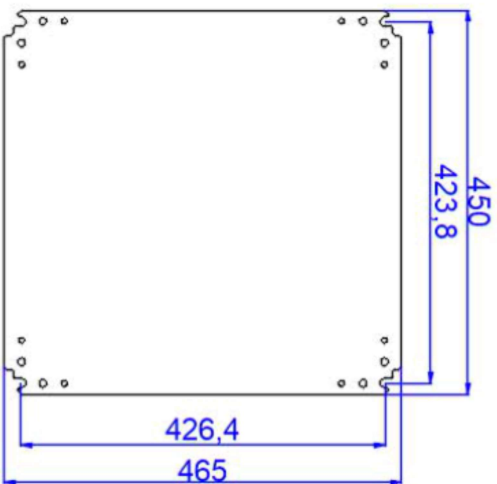
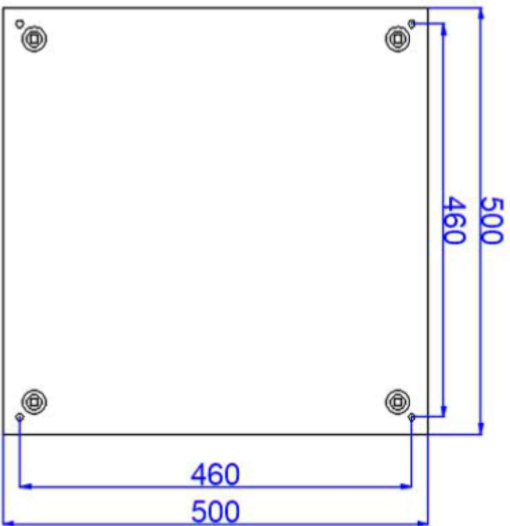
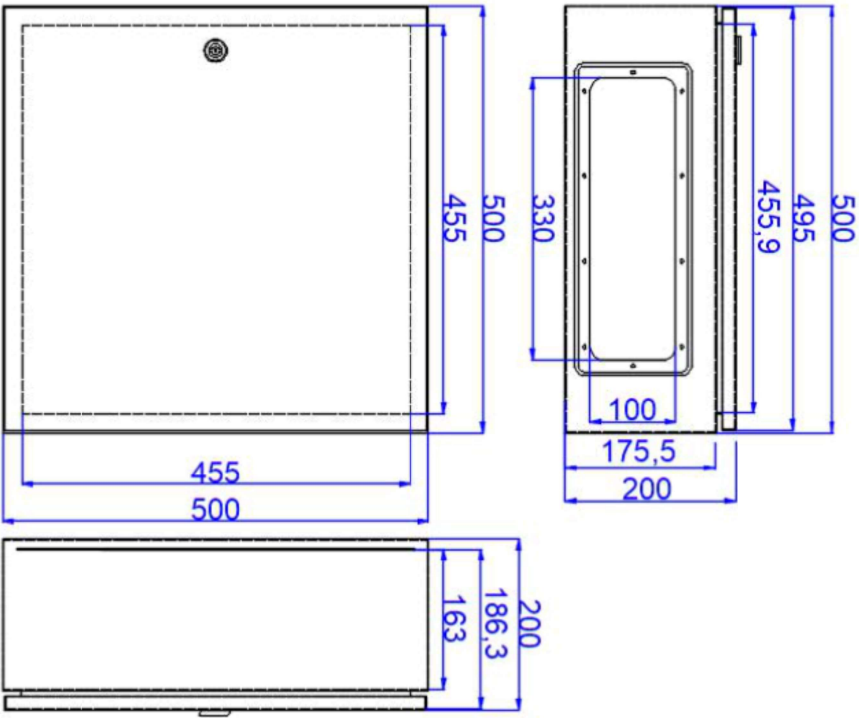

NB: Manufacturers drawings are subject to change without notice